

TECHNICAL DATA

Description

The VELAQUA is an transposition of the Bike in aquatic usage for re-education, pleasure and games. Unsinkable, uncapsizable, it's composed with a U frame and with two floats fixed in a symmetrical position on front and on rear.



It floats naturally with a load of more than 120 kg. The floats give excellent stability in response to the movements of the user who is sits astride the bottom of the frame

The parts are of plastic conforming to swimming pool accessory and sea equipment specifications.

The frame includes orifices allowing its stabilization with the retention of water at the level of the line of flotation.

The floats have ergonomically designed handles that are easily gripped to transmit the effort the user applies to move the whole machine

Two complementary kits of propulsion can be used; the first one with fins acting in alternated movements is ordered by handles on the sides of the user, the other one using two electrical motors (2 x 150 Watts or 2 x 300 Watts) drive by two joysticks

The rounded shapes of the parts reduce the danger of shocks and bruises in case of collisions

The characteristics of the VELAQUA allow its inoffensive usage with users of variable corpulence up to a 120 kg

Assembly and maintenance

- ✓ Simple but efficient lockable fixings (which can't come undone in the water) mean that the three main components of the machine can be easily dismantled and stored.
- ✓ No specific maintenance.

Nomenclature

The parts are of plastic conforming to aquatic accessories specifications.

The material is High Density Polyethylene (HDPE) - mass volume 0,920 ISO 1872/1 and includes approved additives for UV resistance and various aquatic use requirements.

For some parts (feet support and back wheels in option)

The material is Achrylonitril-butadiene-styrene gelignite (ABS) - mass volume 0,950 ISO 1872/1, and includes approved additives for UV resistance and various aquatic use requirements

For all these Parts

The surface treatment is hydrophobic and does not cause any deterioration of the aquatic environment. The parts are resistant to salts and chlorides and are fully recyclable

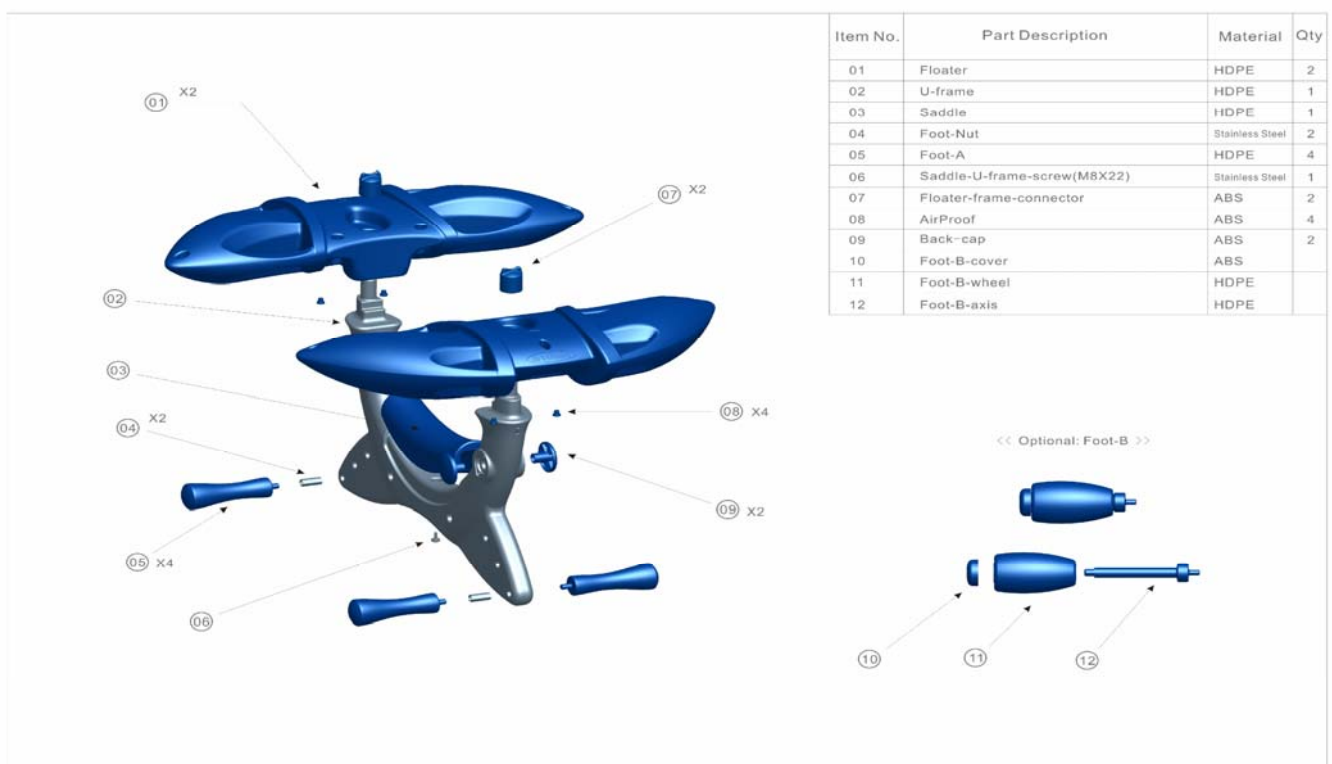

Size and weight

Length : 149 cm - Height : 78 cm - Width : 112 cm - Weight : 14,5 kg.

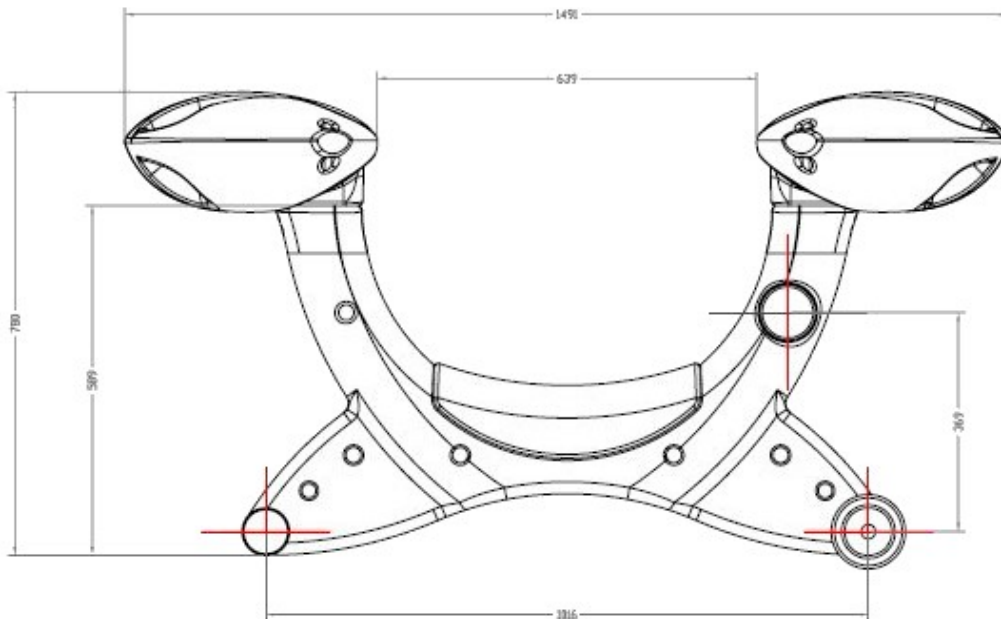

Draft: 0m70 - Minimum Depth for optimal use: 1m50.

Use

The user can change his position from just sitting or for more fun to all the positions the body allows. Propulsion is a choice between pedalling using the fins or using electric motors.

Usage can be allowed for youth with the aptitude to move alone in water. No limitation is to be considered in its use which does not present specific danger by collision or other one.

Her usefulness in the field of re-education and it's particularly recommended to allow the beneficial effects of thermal relaxation with re-educative stimulation movements.

The removable seat can be replaced in a few seconds by an ergonomic seat for persons with reduced agility .

Rapport d'Essai

Aix les Milles, le 17 - avril - 2009

RAPPORT D'ESSAI / *Test report*
AX09-01986.001

Page 1 sur 4

LE VELAQUA DIFFUSION
17 Rue du Colisée

75008 PARIS
FRANCE

A l'attention de M. Vincent SERER

Devis/Convention / *Offer* : DC09-00531

Commande / *Order* :

Produit / *Product* :

VELO AQUATIQUE

Référence / *Reference*

FUN

Marque / *Brand*

LE VELAQUA

Fabricant / *Manufacturer*

LE VELAQUA

Reçu / *Received* :

23/03/2009

Nombre d'échantillons / *Samples #* : 1

Commentaire / *Comments* :

Conclusion / *Conclusion* :



Dans nos conditions d'essais, les échantillons analysés font preuve de caractéristiques satisfaisantes sur les critères considérés : résistance mécanique, stabilité et solidité des coloris à l'eau salée et à l'eau chlorée.

In our test conditions, the tested samples show satisfactory characteristics on the considered criteria: mechanical strength, stability and colourfastness to salted water and chlorinated water.



Jérôme VANNESSON
Expert Technique

(1) Essai sous-traité dans un laboratoire SGS. (2) Essai sous-traité dans un laboratoire n'appartenant pas à notre groupe. Le présent rapport est émis par la société conformément à ses conditions générales de service disponibles sur demande et accessibles sur http://www.sgs.com/terms_and_conditions.htm. Nous attirons votre attention sur les clauses de limitation de responsabilité, d'indemnisation et de compétence judiciaire figurant dans nos conditions générales de service. Tout autre détenteur de ce rapport est informé que son contenu reflète uniquement les faits tels qu'ils sont relevés par la société au moment de son intervention uniquement et le cas échéant dans la limite des instructions reçues par son client. La société n'est tenue responsable qu'envers son client. Ce rapport ne saurait exonérer toute partie à une transaction d'exercer pleinement tous ses droits et remplir ses obligations légales et contractuelles. Toute modification ou reproduction non autorisée ainsi que toute falsification du contenu de ce rapport ou de son apparence est strictement interdite et fera l'objet de poursuites judiciaires dans l'entière mesure autorisée par la loi. A moins que cela ne soit précisé, les résultats de ce rapport ne concernent que le(s) échantillon(s) testé(s) et ces échantillons ne seront conservés que pour une période de 30 jours. Ce document ne doit pas être reproduit, sinon en entier, sans accord préalable écrit de la Société. Il comporte 2 page(s). Pour les clauses énoncées ci-dessus, la version en anglais ci-après fait foi. (1) Test subcontracted in a SGS Laboratory. (2) Test subcontracted in an external laboratory. This document is issued by the Company under its General Conditions of Service available on request and accessible at http://www.sgs.com/terms_and_conditions.htm. Attention is drawn to the limitation of liability, indemnification and jurisdiction issues defined therein. Any holder of this document is advised that information contained herein reflects the Company's findings at the time of its intervention only and within the limits of Client's instructions, if any. The Company's sole responsibility is to its Client and this document does not exonerate parties to a transaction from exercising all their rights and obligations under the transaction documents. Any unauthorised alteration, forgery or falsification of the content or appearance of this document is unlawful and offenders may be prosecuted to the fullest extent of the law. Unless otherwise stated the results shown in this test report refer only to the sample(s) tested and such sample(s) are retained for 30 days only. This document shall not be reproduced, except in full, without prior written approval of the Company. It includes 2 page(s).